

MOUNTING INSTRUCTION 6 STAND SUPPORTS

Drawing signs:

No.1 – screw (6 pcs)

No.2 – stand support (6 pcs)

No.3 – sleeve of stand support

No.4 – screw hole in the stand body

No.5 – cut-out area for support in the stand body

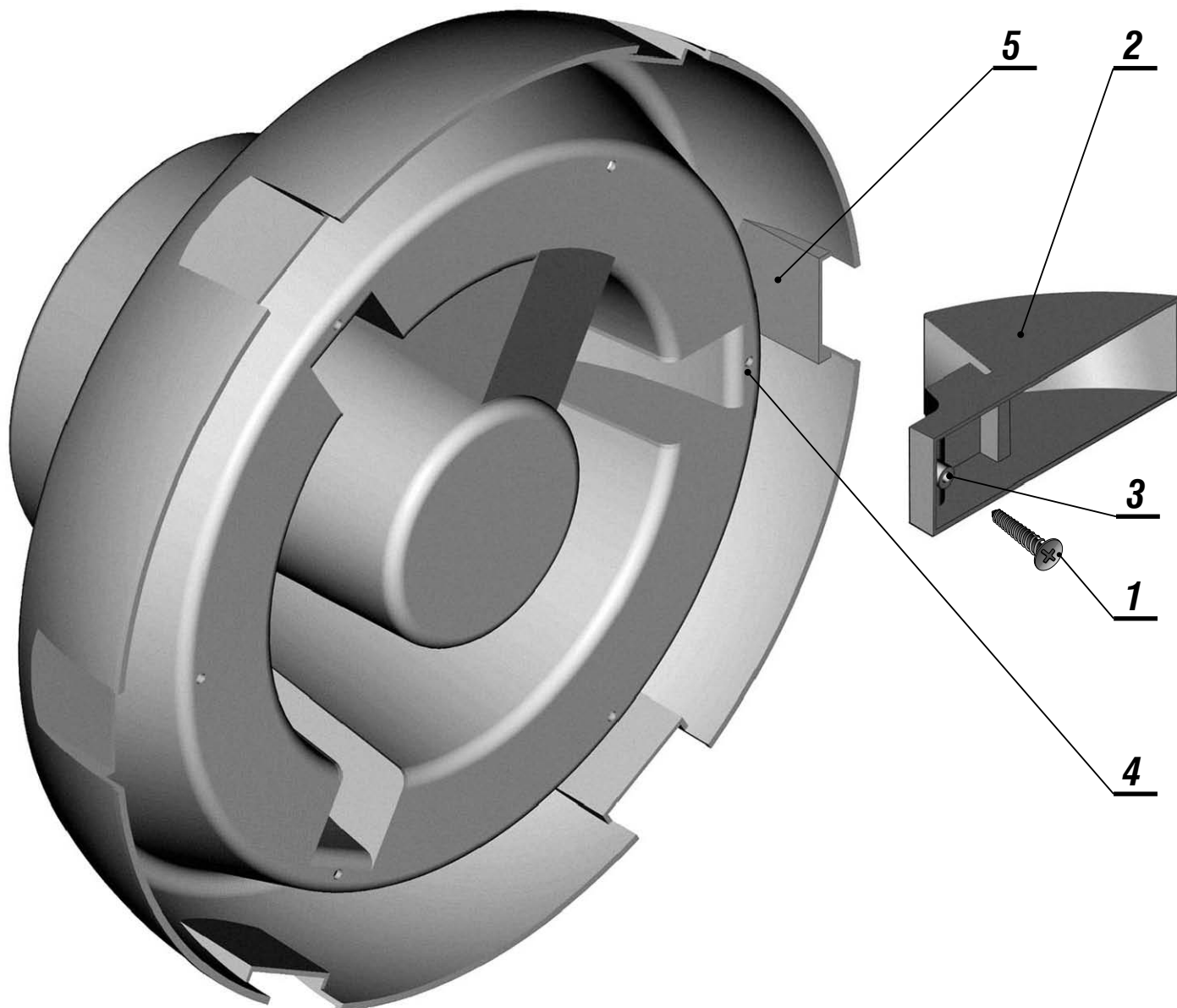

Mounting sequence:

1. Insert all stand supports (2) into cut-out areas in the stand body (5) so that holes of sleeves (3) fit into holes (4) in the stand body.
2. Insert screws (1) into sleeve holes (3).
3. Fasten screws (1) using a Philips screwdriver.